



# MODEL G7114 LONG PLATFORM TRUCK 700 LB CAPACITY INSTRUCTION SHEET

## Specifications

Dimensions..... 48"L x 24"W  
Weight ..... 58 Lbs.  
Capacity..... 700 Lbs.

## Inventory (Figure 1)

	Qty
A. Platform .....	1
B. Swivel Casters.....	2
C. Fixed Casters .....	2
D. Handle .....	1

## Assembly

1. Remove the (16) M10-1.5 x 20 hex bolts, (16) 10mm lock washers, and (16) 10mm flat washers from the bottom of the platform.
2. Install the two swivel casters onto the handle end of the bottom of the platform with eight of the hex bolts, lock washers, and flat washers removed in **Step 1**, as shown in **Figure 2**.
3. Install the fixed casters on the other end with the remaining hardware.
4. Insert the handle into the holes at the end of the platform, as shown in **Figure 3**.

If you need help with your new item, call our Tech Support at: (570) 546-9663.

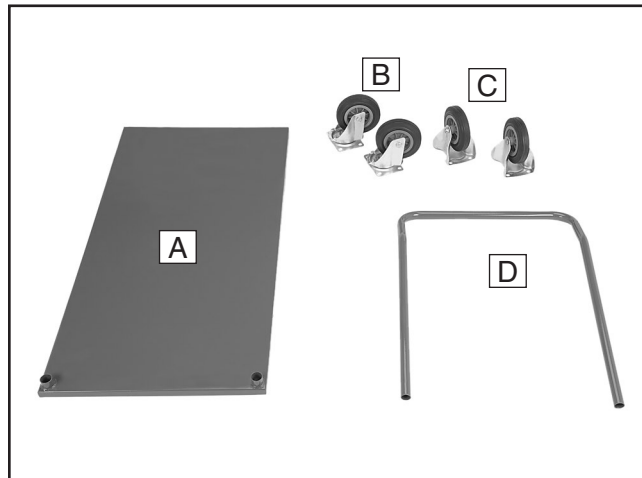

Figure 1. Model G7114.

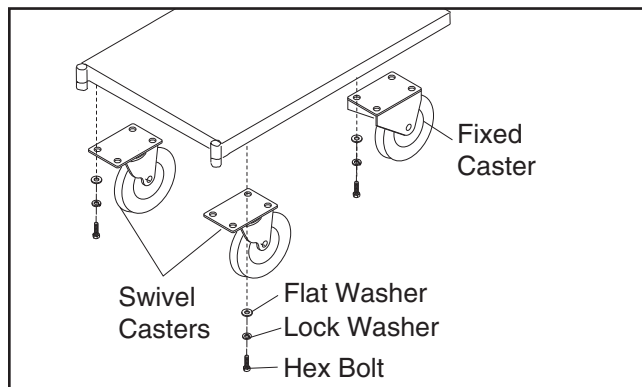

Figure 2. Installing casters.



Figure 3. Handle installed onto platform.

### ⚠ CAUTION

Do not ride or stand on cart. It could stop abruptly or slip out from underneath, resulting in personal injury.

### ⚠ CAUTION

This cart is not a toy. Keep it away from children!

COPYRIGHT © DECEMBER, 2008 BY GRIZZLY INDUSTRIAL, INC.

**WARNING: NO PORTION OF THIS MANUAL MAY BE REPRODUCED IN ANY SHAPE OR FORM WITHOUT THE WRITTEN APPROVAL OF GRIZZLY INDUSTRIAL, INC.**

#BL11402 PRINTED IN CHINA

# G7114 Parts Breakdown and List

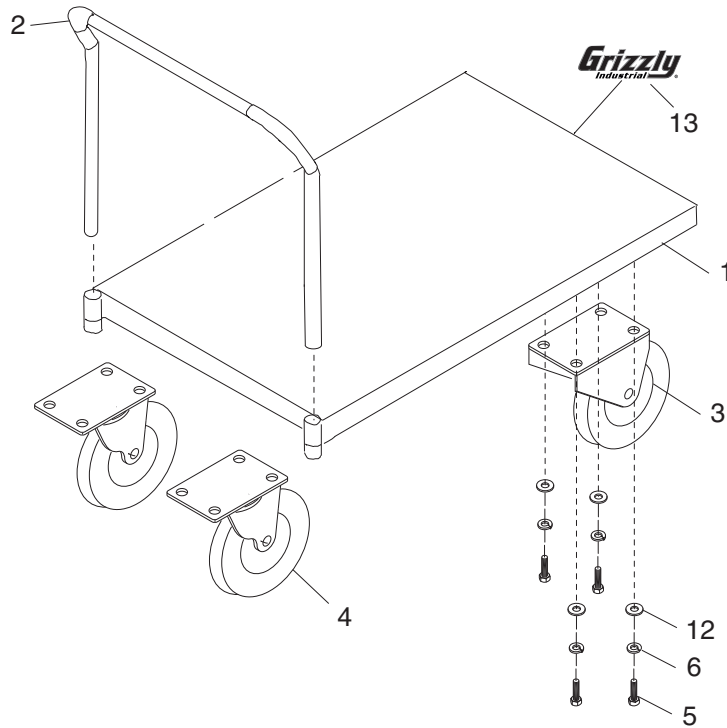

REF	PART #	DESCRIPTION
1	P7114001	PLATFORM
2	P7114002	HANDLE BAR
3	P7114003	FIXED CASTER 6"
4	P7114004	SWIVEL CASTER 6"
5	PB74M	HEX BOLT M10-1.5 X 20
6	PLW06M	LOCK WASHER 10MM
12	PW04M	FLAT WASHER 10MM
13	P7114013	GRIZZLY LOGO

**Note:** Breakdown shown for service purposes only. Not all parts are available for purchase.